



### FLUOR-O-FLO® PTFE Cam-Lock, Quick-Connect Coupling

With Male or Female NPT Connections\*

Made from MICROFLON™ Creep-Resistant PTFE



Product Specifications 2.4-2

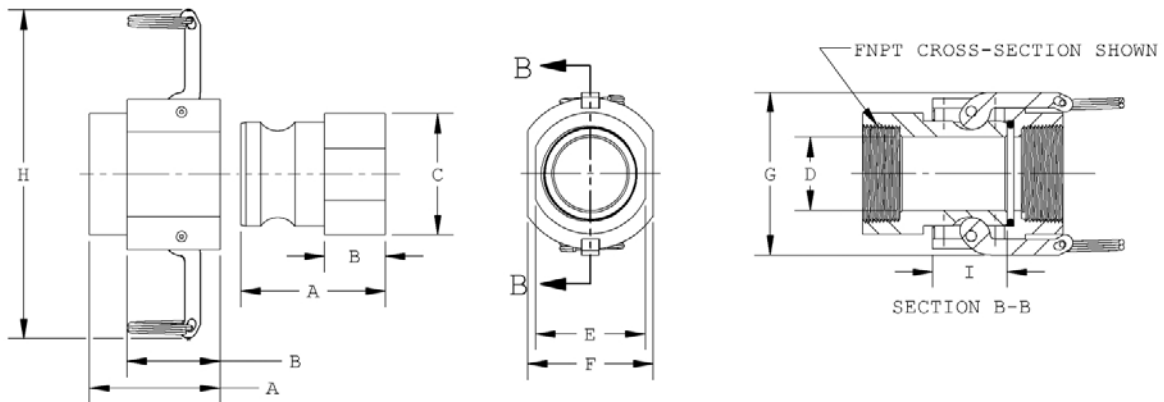

\*Other connections, such as hose barbs, available. Contact factory.

Call today for our  
PTFE Cam-Lock, Quick-Connect Coupling  
Sales Bulletin



Nominal Pipe Size (Inches)	Part Number	Basic Body Size	A	B	C	D	E	F	G	H	Weight (lbs.)
<b>Half-Coupling Type: Male w/Female NPT Threads</b>											
1/4"	CLMFT02	X	2.31	0.83	1.56	0.30	1.40	N/A	N/A	N/A	0.16
3/8"	CLMFT03					0.42					
1/2"	CLMFT04					0.55					
3/4"	CLMFT06	Y	3.21	1.05	1.82	0.74	1.58	N/A	N/A	N/A	0.22
1"	CLMFT08					0.85					
1-1/4"	CLMFT10	Z	3.91	1.46	2.90	1.28	2.63	N/A	N/A	N/A	0.71
1-1/2"	CLMFT12					1.50					
2"	CLMFT16					1.70					
<b>Half-Coupling Type: Male w/Male NPT Threads</b>											
1/4"	CLMMT02	X	2.31	1.18	1.56	0.30	1.40	N/A	N/A	N/A	0.14
3/8"	CLMMT03					0.42					
1/2"	CLMMT04					0.55					
3/4"	CLMMT06	Y	3.21	1.84	1.82	0.74	1.58	N/A	N/A	N/A	0.24
1"	CLMMT08					0.85					
1-1/4"	CLMMT10	Z	3.91	1.91	2.90	1.28	2.63	N/A	N/A	N/A	0.73
1-1/2"	CLMMT12					1.50					
2"	CLMMT16					1.70					
<b>Half-Coupling Type: Female w/Female NPT Threads</b>											
1/4"	CLFFT02	X	2.18	1.30	N/A	0.30	N/A	1.75	2.45	3.62	0.40
3/8"	CLFFT03					0.42					
1/2"	CLFFT04					0.55					
3/4"	CLFFT06	Y	2.97	1.69	N/A	0.74	N/A	2.00	2.26	4.75	0.64
1"	CLFFT08					0.88					
1-1/4"	CLFFT10	Z	3.48	2.23	N/A	1.28	N/A	3.00	3.90	7.80	1.38
1-1/2"	CLFFT12					1.50					
2"	CLFFT16					1.75					
<b>Half-Coupling Type: Female w/Male NPT Threads</b>											
1/4"	CLFMT02	X	2.18	1.30	N/A	0.30	N/A	1.75	2.45	3.62	0.31
3/8"	CLFMT03					0.42					
1/2"	CLFMT04					0.55					
3/4"	CLFMT06	Y	2.97	1.69	N/A	0.74	N/A	2.00	2.26	4.75	0.56
1"	CLFMT08					0.88					
1-1/4"	CLFMT10	Z	3.48	2.23	N/A	1.28	N/A	3.00	3.90	7.80	1.37
1-1/2"	CLFMT12					1.50					
2"	CLFMT16					1.75					

Notes:

- All dimensions given above in inches except weights, which are given in pounds.
- Female half-couplings of either thread type may be combined with male half-couplings of either thread type.
- Half-couplings within each of the three basic body size ranges may be interchanged if needed to mate disparate pipe sizes. Thus, P/N CLFFT02, an X size female half coupling with 1/4" female NPT threads may be combined with P/N CLMMT04, an X size male half-coupling with 1/2" male NPT threads. Nominal sizes 1/2", 1" and 2" can be connected to same size commercially available industry standard systems. To connect other nominal sizes to commercially available industry standard systems please contact factory.
- For pressure versus temperature ratings for each size, see Micromold's FLUOR-O-FLO® PTFE Threaded Piping System Pressure Rating Chart at <http://catalog.micromold.com/asset/fof-pressure-graph-technical-bulletin.pdf>. For pressure ratings, follow the curve for the largest Nominal Pipe Size in the Basic Body Size. (i.e. for Basic Body Size X use 1/2" Nominal Pipe Size.)



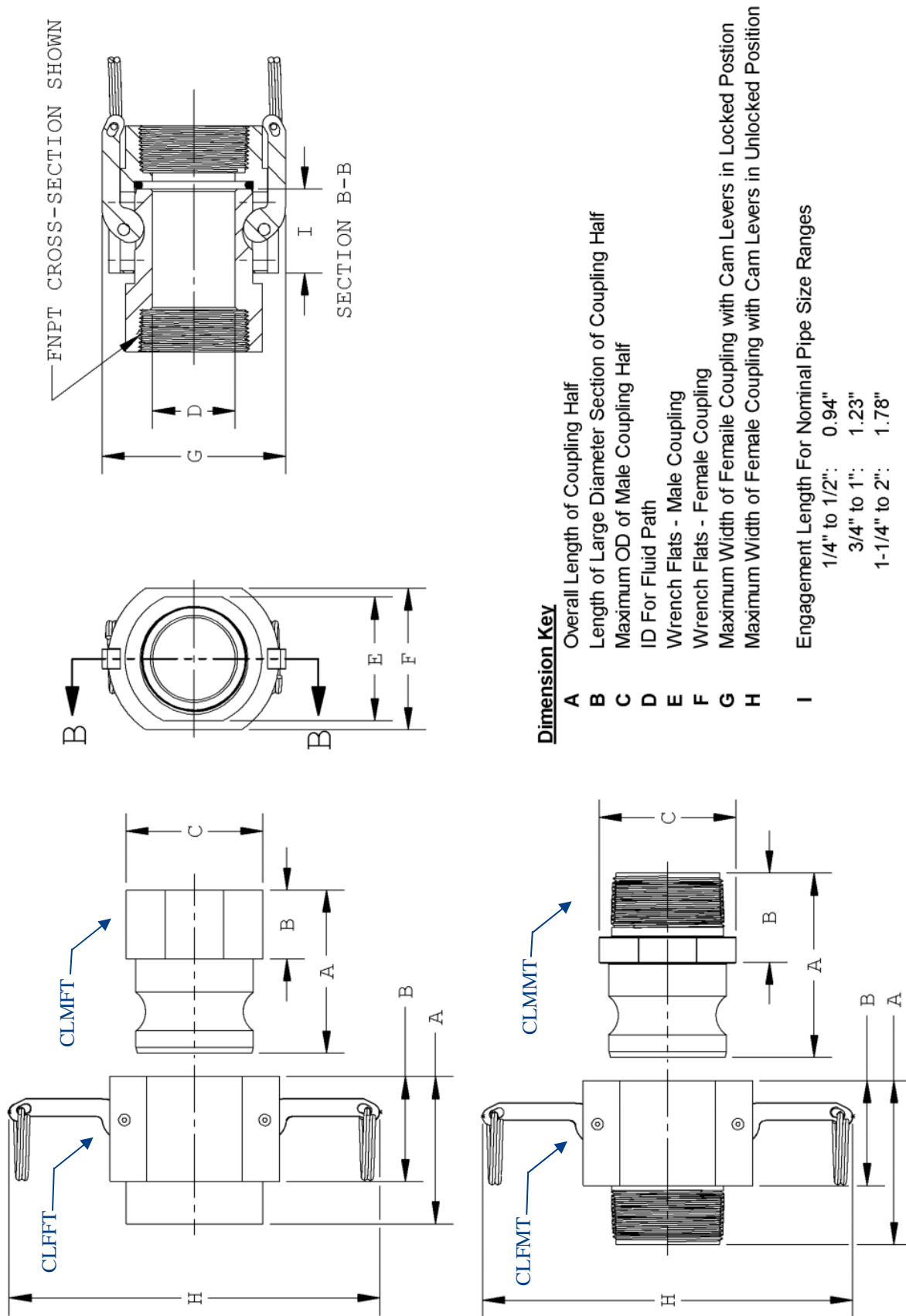

Product Specifications 2.4-2



## Engineering Specifications

All pipe in sizes 1/8" through 2" shall be schedule 80 suitable for NPT threading, and shall be made from virgin PTFE (polytetrafluoroethylene) resin conforming to ASTM D4894 Type V. Fittings having only male NPT threaded end connections shall be made from virgin PTFE resin conforming to ASTM D4894 Type V, or ASTM D4894 Type I Grade 1, and shall have pressure ratings equal to or greater than that of the schedule 80 pipe. Fittings having any female NPT threaded end connections shall be made from MICROFLON™ low-creep virgin PTFE resin conforming to ASTM D4894 Type III, Grade 1, and shall have pressure ratings equal to or greater than that of the schedule 80 pipe.

As in the FLUOR-O-FLO® PTFE Piping System manufactured by Micromold Products, Inc., installation shall be performed in accordance with Micromold's Technical Bulletin: "FLUOR-O-FLO® PTFE Piping System Installation Instructions."

For further information regarding these and other related products, please refer to other MICROMOLD PRODUCTS' publications:

- Technical Bulletin, Pressure Ratings, FLUOR-O-FLO® PTFE Piping System.
- Technical Bulletin, Installation Instructions, FLUOR-O-FLO® PTFE Piping System.
- Sales Bulletin, FLUOR-O-FLO® PTFE NPT Piping System.
- Sales Bulletin, FLUOR-O-FLO® PTFE Tank Adapters (Bulk-head Fittings).
- Sales Bulletin, FLUOR-O-FLO® PTFE Manifolds.
- Sales Bulletin, FLUOR-O-FLO® PTFE Cam-Lock, Quick-Connect Coupling.
- Sales Bulletin, FLUOR-O-SHIELD™ PVDF & PTFE Y-Strainers.
- Sales Bulletin, FLUOR-O-SHIELD™ PVDF & PTFE Basket Strainers.
- Sales Bulletin, FLUOR-O-VALVE™ PTFE Plug Valves.

