

FLUOR-O-FLO® PVDF & PTFE Basket Strainers

Removable PTFE Strainer Cartridge with Fluoropolymer Screen

Flanged • NPT • Socket Weld • Tri-Clamp

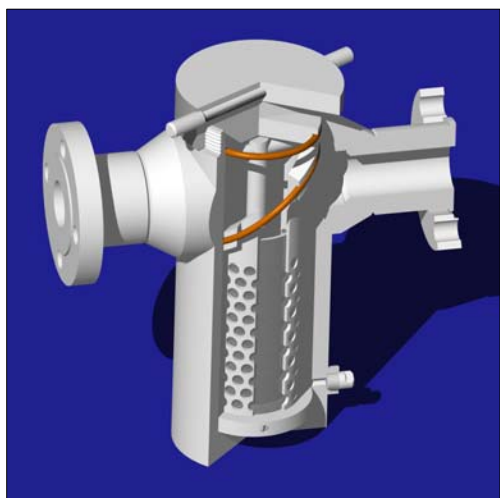

- Available in nominal sizes 1/2" through 3"
- Standard end connections include:
 - * ANSI Class 150 flanged
 - * Socket – IPS or metric sizes (PVDF units only)
 - * Female NPT
 - * Tri-Clamp
 - * Other connections available include ISO metric flanges and true-union
- Particle sizes strained: 1 to 25,400 microns (0.00003" to 1") using either membranes, mesh screens, or drilled holes. Please refer to our *Strainer Screens Technical Bulletin* for details.
- Minimum 6:1 open area ratio when used with 48% or higher open area mesh
- All wetted materials are fluoroplastic:
 - * Body and Connections: Kynar® PVDF or Virgin PTFE
 - * Screen: ETFE or alternates
 - * Cartridges and Drain Plugs: PTFE
 - * Seals: FEP encapsulated silicone rubber o-ring. PFA encapsulated or other o-ring materials can be supplied.

Micromold's PVDF and PTFE Basket Strainers have construction similar to our Y-Strainers, but with higher particulate holding capacity. They are especially well suited for use in removing large volumes of suspended or waste solids from corrosive or high-purity fluid streams. They help prevent damage to sensitive downstream process components such as pumps, valves, instruments, and spray nozzles. The benefits of our special design include:

- **Extreme Corrosion Resistance** - All fluoroplastic construction that provides superior corrosion resistance when compared with PVC, CPVC, or polypropylene units. Teflon® FEP encapsulated o-ring seals prevent blow-by and external leakage.
- **Convenience** - Screw top allows easy strainer cartridge removal and clean-out. Drain-plug allows drainage of residual liquids before cartridge removal. Both PTFE and PVDF strainers feature a removable, and easily cleaned PTFE cartridge with Fluoropolymer screen and FEP encapsulated silicone o-ring to prevent blow by.
- **Flexibility** - Available with a wide range of mesh screens and connections.

Also available:

FLUOR-O-FLO® PVDF & PTFE Basket Strainers

- Product Specifications
- Installation and Maintenance Guide
- Strainer Screens Technical Bulletin